

# Chute Magnet

## At A Glance



**Protection: Primary**



**Feed Type: Gravity**



**Material Type: NdFeb**



**Cleaning Type: Manual**

**Our high intensity magnetic chute magnet has been designed to operate in arduous conditions and where contamination size is relatively large e.g. nuts, bolts etc.**

The unit has two hinged, high intensity magnetic packs, which are secured to a housing by an adjustable hinge arrangement and tri-cone locking nut. These tri-cone nuts ensure even pressure is generated around the food grade silicon seal.

The chute magnet can be incorporated into any form of vertical or angled pipe or chute section. A common installation location is raw material inlet points for products such as grain, rice, corn, bran and animal feed etc. A central diverter is mounted on the inlet. This directs processed product onto the magnetic face ensuring a high contamination removal rate.



## Benefits

- Easy to clean
- Reduces 'spark' risk
- Rare Earth deep magnetic field
- High collection capacity
- Meets audit requirements
- Removes 'tramp' sized contaminants

## Performance

Magnetic Performance	3,500 Gauss
Performance Reading	On magnetic pack face
Magnet Grade	N35 – Inspected and confirmed via hystero-graph prior to use
Temperature	-20°C / +90°C
Pressure	+ / - 0.2 Bar

## Suitability

Suitable Products	Dry powders and granulates
Suitable Location	Inlet / outlet points

## Materials

Magnetic Material	Rare Earth Neodymium Iron Boron - (NdFeb)
Housing	304 grade stainless steel
Other Parts	304 grade stainless steel
Toggle Clamps	Stainless Steel
Sealing	Self adhered white foam (FDA)
Surface Finish	Bead Blasted

## Cleaning

The chute magnet uses our 'easy clean' system. Simply release the quick-release toggle clamps, swing the packs away from the line and hinge the easy clean plates away. The collected contamination will be free from magnetic attraction and can be simply and easily removed allowing for inspection or further analysis.

## Options

- Overpressure to + / - 5 Bar
- Pharmaceutical specification
- Metal detectable silicon rubber seal – dark blue, FDA approved
- Higher gauss versions available
- Sizes up to 500mm Ø or square
- ATEX certified

# Chute Magnet

Round

Square

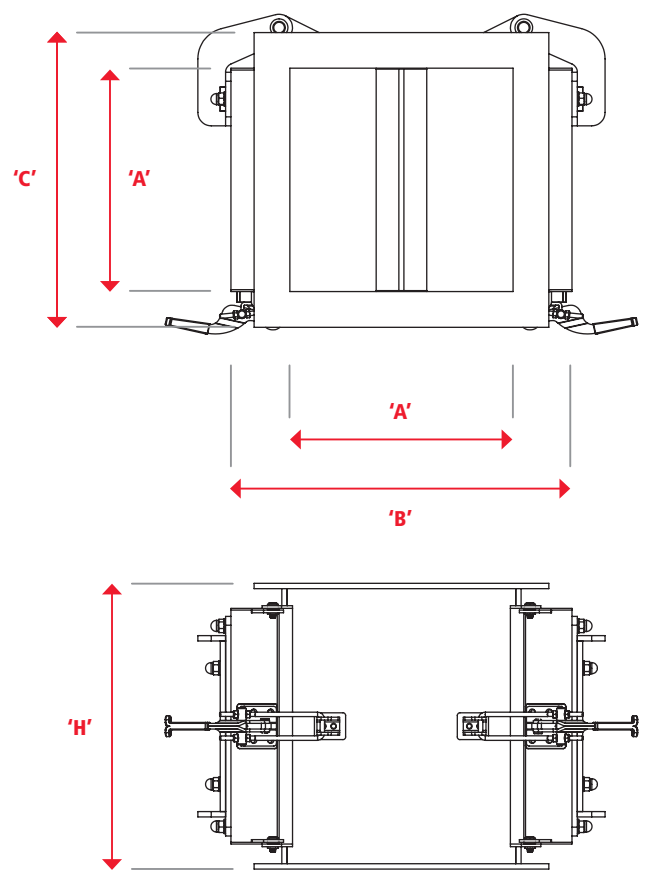
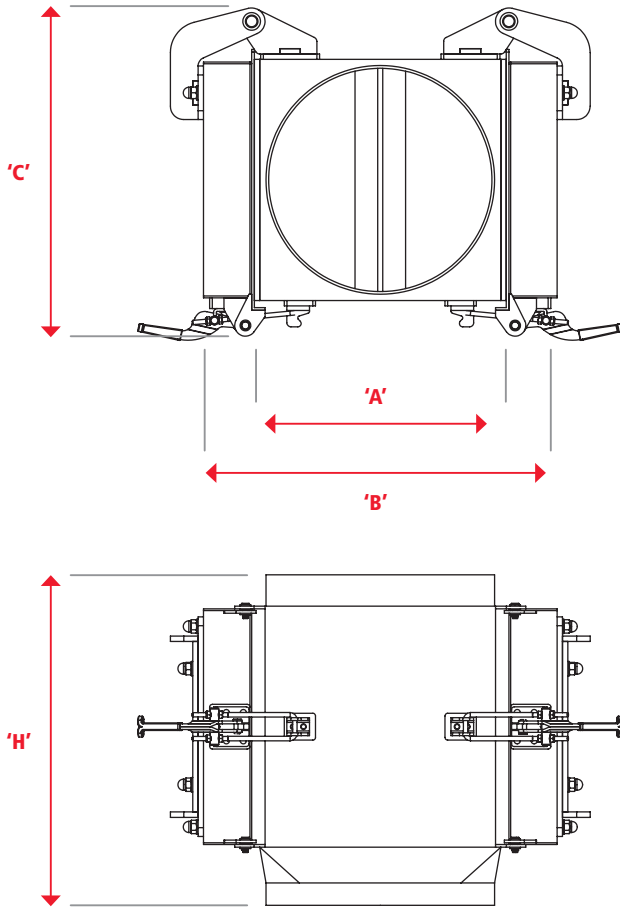

Part Number (Round)	Inlet / Outlet A (mm)	B (mm)	C (mm)	H (mm)	Weight (kg)
CMN150	150	350	250	270	24
CMN200	200	400	300	270	32
CMN250	250	500	380	370	42
CMN300	300	550	420	370	56
CMN350	350	600	470	370	76

Part Number (Square)	Inlet / Outlet A (mm)	B (mm)	C (mm)	H (mm)	Weight (kg)
CMN1515	150 x 150	280	230	220	22
CMN2020	200 x 200	330	280	220	30
CMN2525	250 x 250	380	330	320	39
CMN3030	300 x 300	450	380	320	52
CMN3535	350 x 350	480	430	350	72

For non-standard sizes, please contact [sales@eclipsemagnetics.com](mailto:sales@eclipsemagnetics.com)